



K

Dune Series Landscape Containers

Notable alternatives for distinguished projects

Tapered round precast concrete with shaped top surface.

TO SPECIFY:

- Select the Dune Series and the product number.

Select Concrete Color:

- Natural Gray concrete or choose integral pigment color from Davis Colors (www.daviscolors.com), call/email us for a Davis Colors selector brochure.
- Custom color mixing available.

Choose Drainage hole size:

- Standard 1" approximately.
- Custom Size to function with irrigation & drainage (note size of plumbing fixture to be used).
- No drainage hole.



Chosen by *Architectural Record* as one of the outstanding products of 2005.

Note: matching Dune Trash Receptacle / Planter

Optional

- Bituminous Sealer (suggested for interior applications).

See website to download CSI specifications

All weights are approximate

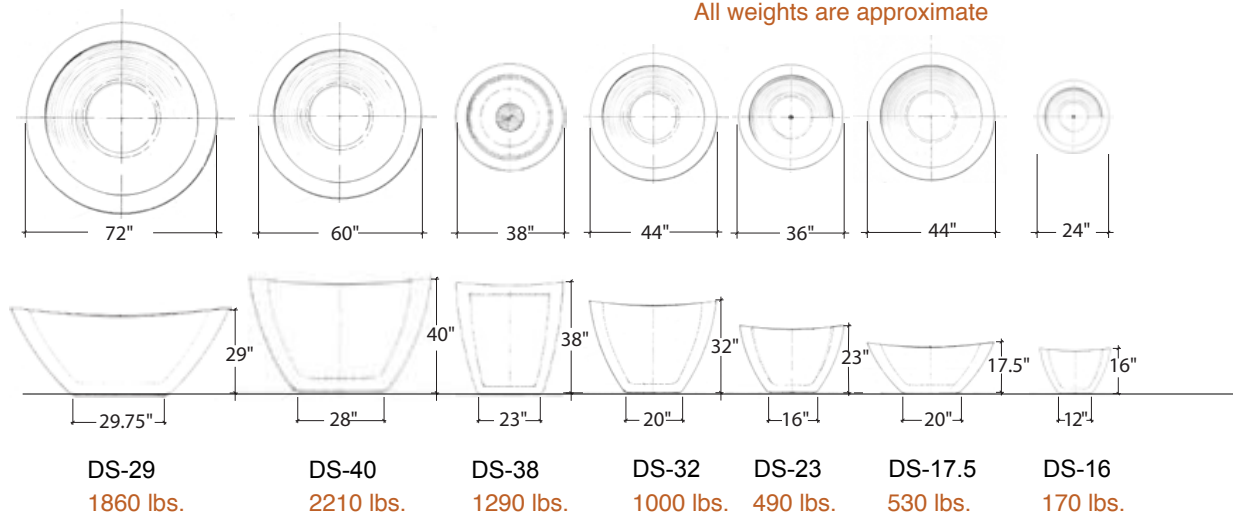

877.252.6323 toll free 602.252.6323 local 602.252.6322 fax 212 South 18th Street, Phoenix, AZ 85034
Kornegay Design is dedicated to exceptional design & craftsmanship of cast concrete site amenities