



K

Dune Trash & Ash Commercial Receptacles

Exceptionally durable precast concrete Trash & Ash Receptacles. Litter lids and ash insert are made of clear powder-coated spun aluminum.

Metal components are fitted with security chains.

A 32-gallon heavy-duty plastic waste can is included.

TO SPECIFY A DUNE SERIES TRASH & ASH RECEPTACLE:

Select the type of lid:

- Model DS-TR is a litter only lid
- Model DS-TRA is a lid with the ash disposal channel

Select Concrete Color:

- Natural Gray concrete
- choose integral pigment from Davis Colors (www.daviscolors.com), call/email us for a Davis Colors selector brochure.
- Custom color mixing available (please contact us).

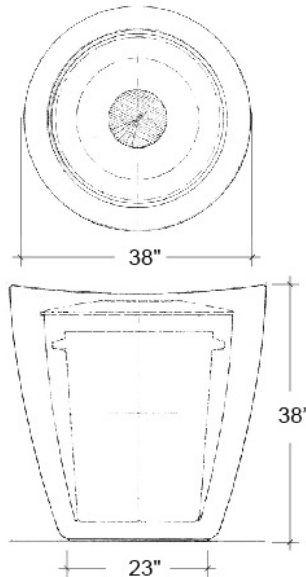

DS-TR • DS-TRA

1300 lbs.

Notable alternatives for distinguished projects



Note: Compatible Dune Series Landscape Containers

See website to download CSI specifications

All weights are approximate