



Faceted Series

Landscape Containers

Tapered architectural precast concrete with faceted face patterns.

TO SPECIFY:

- Select the Faceted Series and the product code.

Choose Drainage hole size:

- Standard diameter approximately 1-1/4" .
- Custom Size to function with irrigation & drainage (note size of plumbing fixture to be used).
- No drainage hole.

Select Concrete Color:

- Natural Gray concrete.
- Choose integral pigment color from Davis Colors (www.daviscolors.com), call/email us for a color selector brochure.
- Custom color mixing available (please contact us).

Optional

- Bituminous Sealer applied to interior of planter (suggested for interior applications).
- Sandblast finish.

See website to download CSI specifications

In 1999[®], Larry Kornegay designed the Faceted Series exclusively for Kornegay Design, LLC

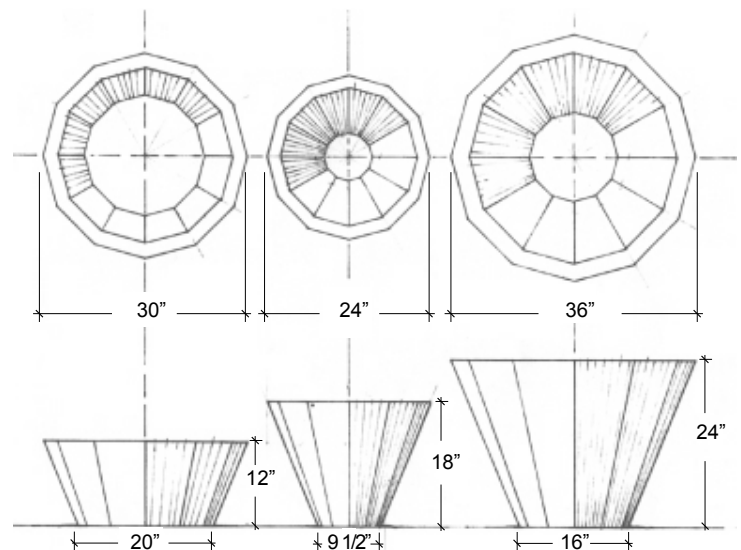

FS-12
180 lbs.

FS-18
110 lbs.

FS-24
350 lbs.

All weights are approximate

877.252.6323 toll free 602.252.6323 local 602.252.6322 fax 212 South 18th Street, Phoenix, AZ 85034
Kornegay Design is dedicated to exceptional design & craftsmanship of site furnishings

www.kornegaydesign.com

info@kornegaydesign.com