



K

KORNEGAY DESIGN cast concrete planters

Masaru Series Landscape Containers

Notable alternatives for distinguished projects

Tapered round precast concrete planter with one or two horizontal scored bands. Planter rims are slightly sloped.

TO SPECIFY:

- Select the Masaru Series and the product number.

Select Concrete Color:

- Natural Gray concrete or choose integral pigment color from Davis Colors (www.daviscolors.com), call/email us for a Davis Colors selector brochure.
- Custom color mixing available.

Choose Drainage hole size:

- Standard 1" approximately.
- Custom Size to function with irrigation & drainage (note size of plumbing fixture to be used).
- No drainage hole.

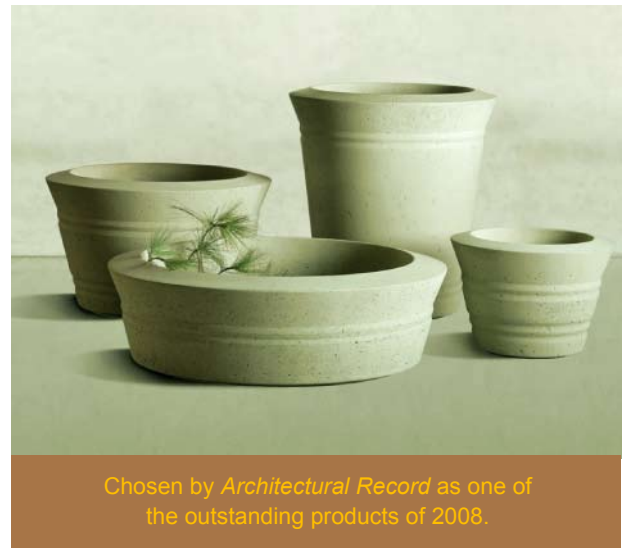

Optional

- Bituminous Sealer (suggested for interior applications).

See website to download CSI specifications

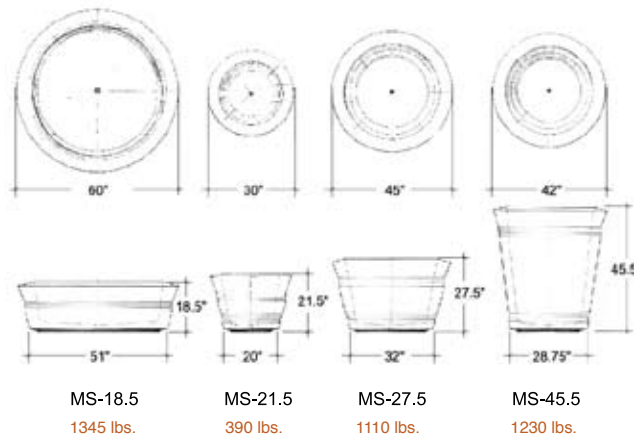

All weights are approximate

877.252.6323 toll free 602.252.6323 local 602.252.6322 fax 212 South 18th Street, Phoenix, AZ 85034
Kornegay Design is dedicated to exceptional design & craftsmanship of cast concrete site amenities

www.kornegaydesign.com