



Quartz Series Landscape Containers

Notable alternatives for distinguished projects

6 sided tapered architectural precast concrete
with multi-faceted face patterns.

TO SPECIFY:

- Select the Quartz Series and the product number.

Select Concrete Color:

- Natural Gray concrete or choose integral pigment color from Davis Colors (www.daviscolors.com), call/email us for a Davis Colors selector brochure.
- Custom color mixing available.

Choose Drainage hole size:

- Standard 1" approximately.
- Custom Size to function with irrigation & drainage (note size of plumbing fixture to be used).
- No drainage hole.

Optional

- Bituminous Sealer (suggested for interior applications).

See website to download CSI specifications



Custom colors shown in picture

■ azurite ■ citrine ■ topaz ■ amethyst

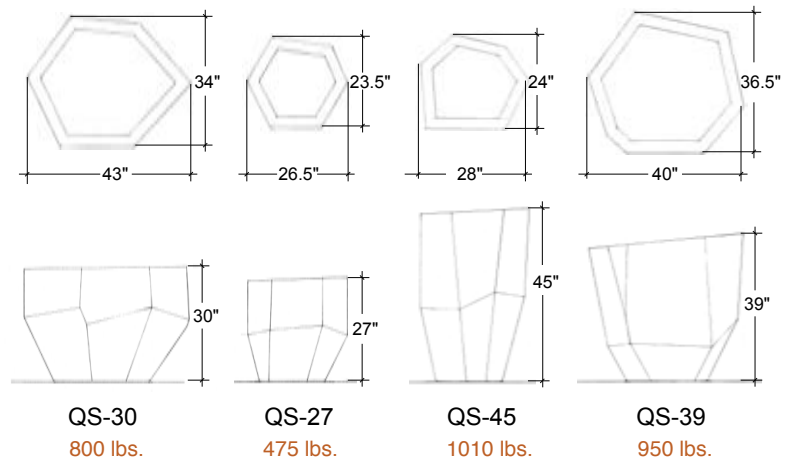

All weights are approximate

877.252.6323 toll free 602.252.6323 local 602.252.6322 fax 212 South 18th Street, Phoenix, AZ 85034
Kornegay Design is dedicated to exceptional design & craftsmanship of cast concrete site amenities

www.kornegaydesign.com